

PEDESTRIAN RAILING

TYPE - 677

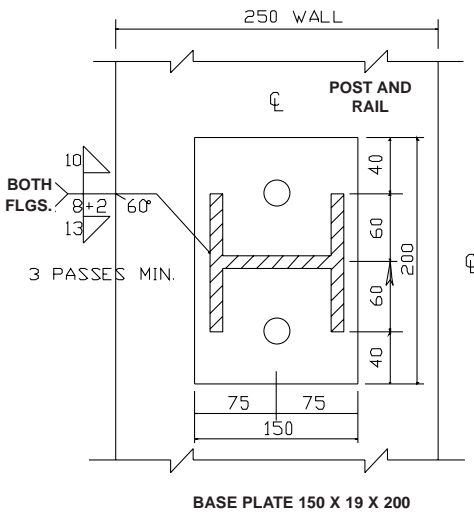

Metals Inc.

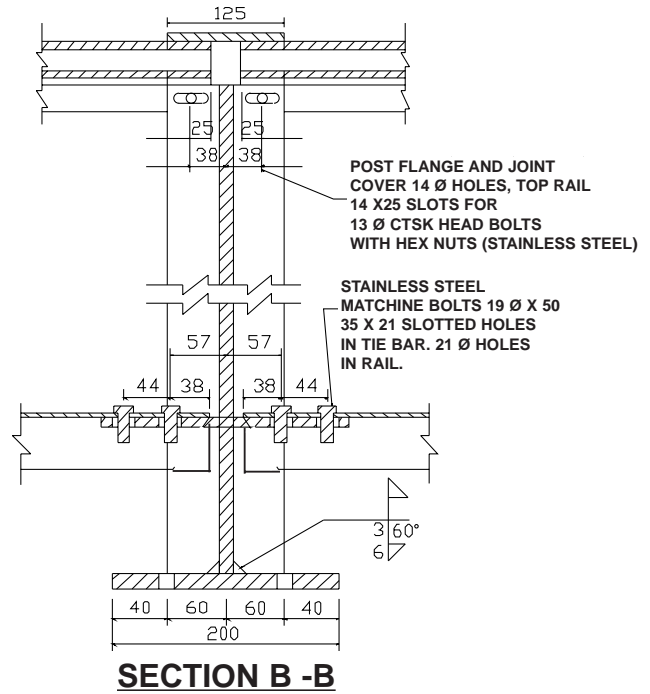
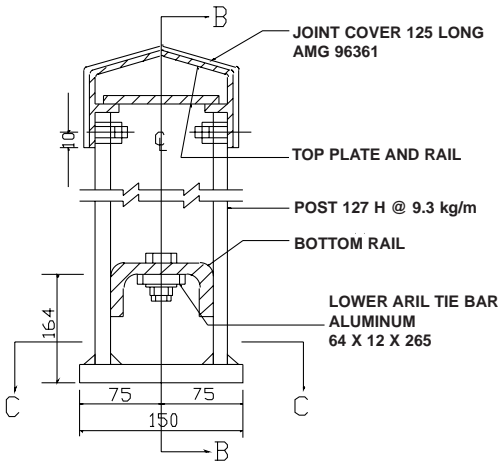
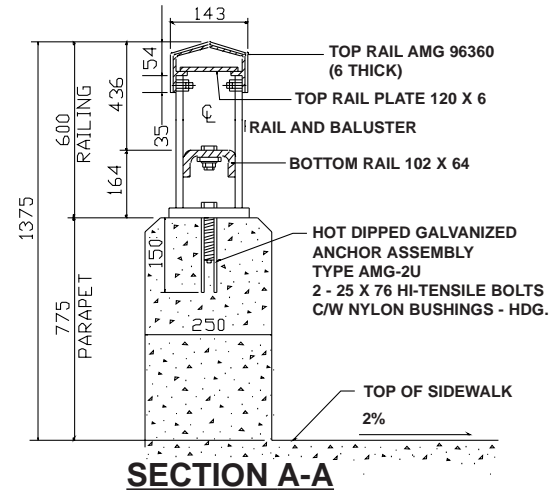
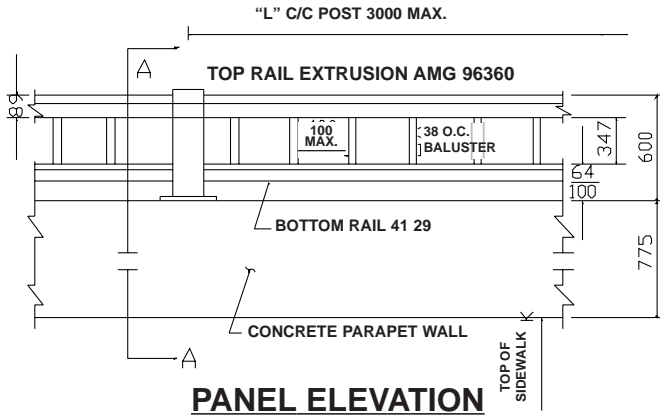

NOTES:
 - PAINT BOTTOM OF BASE PLATE WITH ASPHALT MASTIC.
 - POST AND BALUSTERS TO BE VERTICAL. TOP AND BOTTOM RAILS TO BE PARALLEL TO TOP OF CONCRETE.

MATERIAL	USE	SPECIFICATIONS
ALUMINUM - EXTRUDED SHAPES	POST AND RAILS	6351-T6
ALUMINUM - TUBING	BALUSTERS	6351-T6
ALUMINUM - SHEET AND PLATE	TOP BASE AND TIE PLATES	6061-T6
STAINLESS STEEL TYPE 304	BOLTS, SET SCREW NUTS AND WASHERS	A.S.T.M. - A296 304